



SAFARI
BELTING SYSTEMS

LF-F3000B TAB

Side Flexing Knuckle Chain

DIMENSION	INCH	mm
P	2.00	50.8
W	2.79	70.9
H	0.8	20.4
F	0.4	10.2



Plate Materials: POM-LF
Pin Material: 304 Stainless Steel

CHARACTERISTICS	WIDTH W		CHAIN STRENGTH		TEMPERATURE		WEIGHT	
	mm	inch	kg	lb	°C	°F	kg/m	lb/ft
LF-3000A TAB	70.9	2.79	254	560	-46 to 93	-50 to 200	1.25	.90

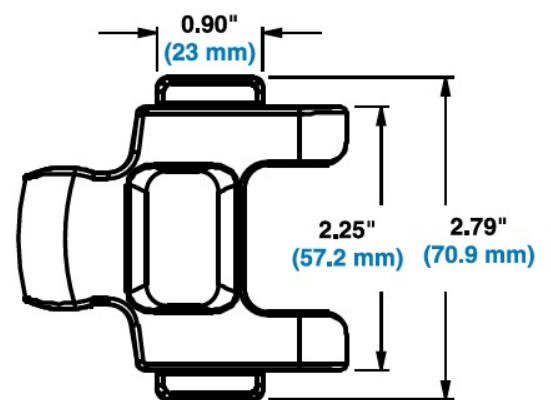
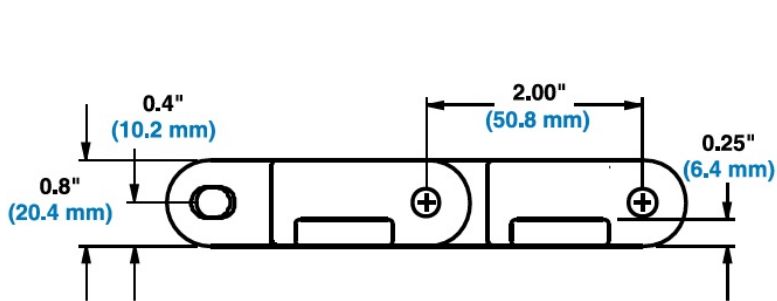

SAFARI Belting Systems, Inc.

900 East Loula | Olathe, Kansas 66061 USA

info@safaribelting.com | (913) 254-7582

www.safaribelting.com

Toll Free (888) 662-6611

Toll Free Fax (888) 234-3070

Competitively Priced. Customer Driven. Quality Focused.